

iQ500, Built-In Microwave BE525LMS0



38 cm high built-in microwave for defrosting, reheating or preparation of dishes in the shortest possible time.

- ✓ Automatic programs ensure best results - cookControl8.
- ✓ For fast cleaning dirt is softened beforehand by vaporizing soapy water. It can then be removed more easily – humidClean.
- ✓ Foods are evenly browned - grill function.
- ✓ Allows the temperature to be controlled by entering it directly or by moving the slider with a single finger - touchControl.
- ✓ Time-saving and powerful up to 800 watts - Wattage.

Features

Technical Data

Type of micro-wave oven : MW+Grill function
 Type of control : Electronic
 Color / Material Front : Stainless steel
 Dimensions : 382 x 594 x 317 mm
 Cavity dimensions : 201.0 x 308.0 x 282.0 mm
 Length electrical supply cord : 130 cm
 Net weight : 16.9 kg
 Gross weight : 19.2 kg
 EAN code : 4242003805640
 Maximum micro-wave power : 800 W
 Connection Rating : 1270 W
 Fuse protection : 10 A
 Voltage : 220-230 V
 Frequency : 50 Hz
 Plug type : Gardy plug w/ earthing
 Cavity dimensions : 201.0 x 308.0 x 282.0 mm
 Included accessories : 1 x grid, 1 x Turntable

Included accessories

- 1 x grid
- 1 x Turntable



iQ500, Built-In Microwave BE525LMS0

Features

Microwave and heating mode:

- Max. Power: 800 W; 5 Microwave power settings: 90 W, 180 W, 360 W, 600 W, 800 W
- Grill 1 KW
- Grill and microwave power levels 90 W, 180 W, 360 W combinable
- Microwave and grill for separate use
- Cavity volume: 20 l

Design:

- stainless steel cavity

Cleaning:

- humidClean (manually)

Comfort:

- LED display
- electronic clock
- Touchcontrol, touchSlider
- User-friendly electronics: extremely
- easy and comfortable operation
- cookControl 8
- 4 defrost and 3 cooking programmes in microwave function, 1 programmes for combination function
- Memory for individual programmes (1 setting)
- LED illumination
- 25.5 cm glass turntable
- side opening door, hinge left
- Electronic door opener
- Touch key operation

Accessory:

- 1 x Turntable, 1 x grid

Environment and Safety:

- Door contact switch
-
- Integral cooling fan

Technical Information

- Length of mains cable: 130 cm
- Total connected load electric: 1.27 KW
- Nominal voltage: 220 - 230 V
- suitable for high cupboard installation, can be built in a 60 cm wall cupboard (at least 30 cm deep)

Dimensions:

- Appliance dimension (HxWxD): 382 mm x 594 mm x 317 mm
- Niche dimension (HxWxD): 362 mm - 365 mm x 560 mm - 568 mm x 300 mm
- "Please reference the built-in dimensions provided in the installation drawing"

iQ500, Built-In Microwave BE525LMS0

Dimensioned drawings

Microwave,
corner installation

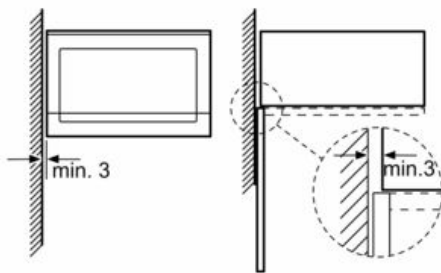

Measurements in mm

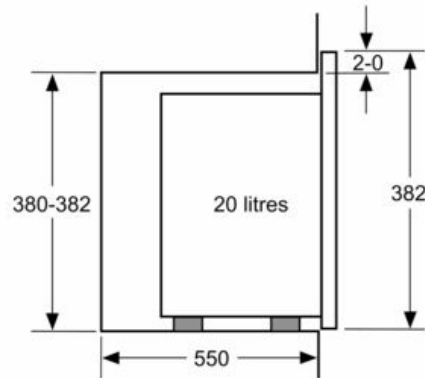

measurements in mm

measurements in mm

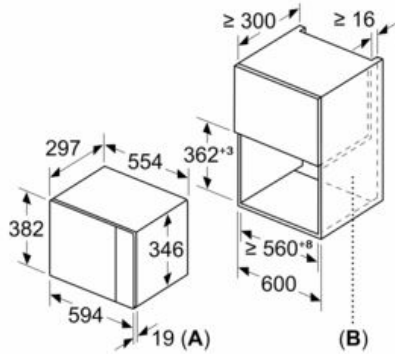

A: 20 mm for metal fascia
B: Back panel open

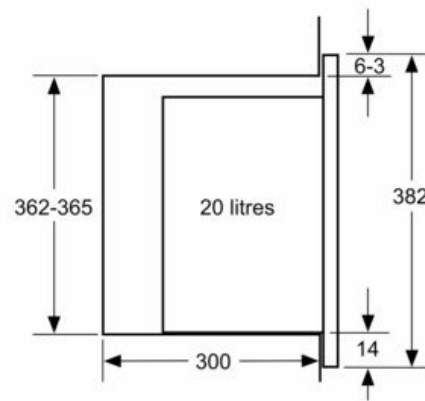

measurements in mm

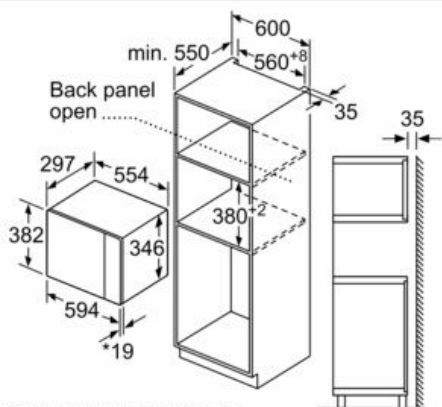

* 20 mm for metal fascia

measurements in mm