

iQ500 Built-in microwave oven BF555LMS0B, Stainless steel



38 cm high built-in microwave for defrosting, reheating or preparation of dishes in the shortest possible time.

- ✓ cookControl7: automatic programs ensure best results.
- ✓ Wattage: time-saving and powerful up to 900 watts.
- ✓ LED-Illumination: ideal energy-efficient illumination.
- ✓ The touchControl allows the temperature to be controlled by entering it directly or by moving the slider with a single finger.
- ✓ The side-opening hinged door: ideal for elevated installation.

Features

Technical Data

Type of micro-wave oven : MW only
 Type of control : Electronic
 Color / Material Front : Stainless steel
 Dimensions of the product (mm) : 382 x 594 x 388
 Cavity dimensions (mm) : 208.0 x 328.0 x 369.0
 Length electrical supply cord (cm) : 130
 Net weight (kg) : 19.0
 Gross weight (kg) : 20.0
 Maximum micro-wave power (W) : 900
 Number of Power Levels : 5
 Turntable : Yes
 Heating type : Microwave
 Cavity material : Stainless steel
 Door opening : Button
 Clock : Yes
 Included accessories : 1 x Turntable
 Main colour of product : Stainless steel
 Height of the product (mm) : 382
 Width of the product (mm) : 594
 Depth of the product : 388
 Maximum micro-wave power (W) : 900
 Connection Rating (W) : 1450
 Current (A) : 10
 Voltage (V) : 230-240
 Frequency (Hz) : 50
 Plug type : GB plug
 Color / Material Front : Stainless steel
 Approval certificates : CE
 Required cutout/niche size for installation (in) : x x
 Appliance Dimensions (h x w x d) (in) : x x
 Dimensions of the packed product (in) : 17.71 x 17.71 x 25.59
 Net weight (lbs) : 41
 Gross weight (lbs) : 45

Included accessories

1 x Turntable



Optional accessories

HZ86D000 Steamer Cooker Accessory for Microwave

iQ500

Built-in microwave oven

BF555LMS0B, Stainless steel

Features

Microwave and heating mode:

- Max. Power: 900 W; 5 Microwave power settings: 90 W, 180 W, 360 W, 600 W, 900 W
- Cavity volume: 25 l

Design:

- Stainless steel cavity

Comfort:

- LED display
- electronic clock
- Touch control
- User-friendly electronics: extremely easy and comfortable operation
- cookControl7
- 4 defrost and 3 cooking programmes in microwave function
- memory function (1 setting)
- LED illumination
- 31.5 cm glass turntable
- side opening door, hinge left
- Electronic door opener

Accessory:

- 1 x Turntable

Environment and Safety:

- Automatic safety switch off
Door contact switch
- Integral cooling fan

Technical Info:

- Length of mains cable: 130 cm
- Total connected load electric: 1.45 KW
- Nominal voltage: 230 - 240 V
- Suitable for high cupboard installation

Dimensions:

- Appliance dimension (hxwxd): 382 mm x 594 mm x 388 mm
- Niche dimension (hxwxd): 380 mm - 382 mm x 560 mm - 568 mm x 550 mm
- "Please reference the built-in dimensions provided in the installation drawing"

iQ500
Built-in microwave oven
BF555LMS0B, Stainless steel

Dimensioned drawings

Microwave,
corner installation

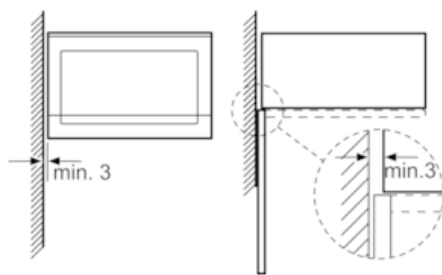

Measurements in mm

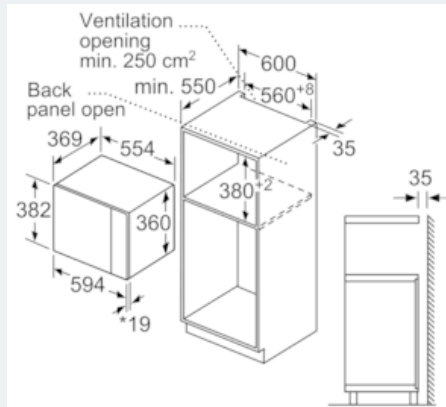

measurements in mm

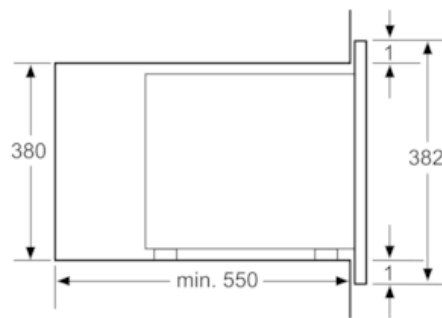

measurements in mm

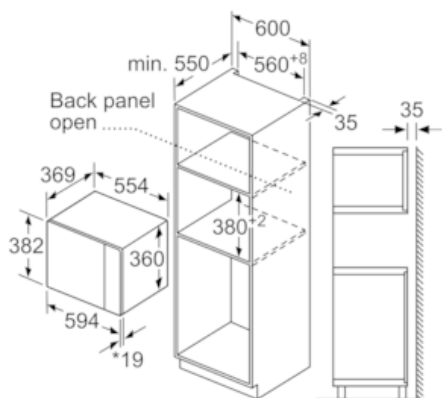

* 20 mm for metal fascia

measurements in mm