

## iQ700, downdraft hood, 80 cm, clear glass LD88WMM66



The seamlessly designed glassdraftAir is only visible when in use, with an impressive performance thanks to the new Guided Air technology.

- ✓ Excellent extraction performance from all cooking zones – powered by iQdrive and Guided Air technology.
- ✓ Flexible installation for optimal use of space – glassdraftAir system.
- ✓ Highlight your kitchen – emotionLight Pro.
- ✓ Powerful and quiet steam extraction – iQdrive motor
- ✓ The power level and the light of your hood can be adjusted by your cooktop - cookConnect system.

### Features

#### Technical Data

Approval certificates : CE, VDE  
 Length electrical supply cord (cm) : 130  
 Required niche size for installation (HxWxD) : 703mm x 781.0mm x 123mm  
 Net weight (kg) : 41.196  
 Type of control : Electronic  
 Number of speed settings : 3-stage + 2 intensive  
 Maximum output air extraction (m<sup>3</sup>/h) : 501  
 Boost position output recirculating (m<sup>3</sup>/h) : 562.0  
 Maximum output recirculating air (m<sup>3</sup>/h) : 447  
 Boost position air extraction (m<sup>3</sup>/h) : 775  
 Noise level (dB) : 62  
 Diameter of air outlet (mm) : 150  
 Grease filter material : Washable stainless steel  
 EAN code : 4242003877302  
 Connection Rating (W) : 300  
 Current (A) : 10  
 Voltage (V) : 220-240  
 Frequency (Hz) : 50; 60  
 Plug type : GARDY plug w/ earthing  
 Installation typology : Built-in

### Optional accessories

LZ28WWY12 : Mounting kit for seamless installation , LZ21WWM11 : Installation kit remote motor , LZ21WWJ11 : Long Life recirculation kit , LZ21WWI16 : Clean Air Plus recirculation kit , LZ21WWB16 : Clean Air Plus odor filter (replacement) , HZ9VDS51 : Connector sleeve (female) , HZ9VDSM2 : Straight tube 1000mm , HZ9VDSM1 : Straight tube 500mm , HZ9VDS11 : 90° Adapter round-flat , HZ9VDS10 : Adapter round-flat , HZ9VDSB2 : 90° flat duct L vertical , HZ9VDSB1 : 90° flat duct bend horizontal



4 242003 877302

## iQ700, downdraft hood, 80 cm, clear glass LD88WMM66

### Features

#### Variant

- 80 cm wide
- For installation in a kitchen cabinet
- The perfect unit (appliance) for installation in an island or Semi-island kitchen solution
- Suitable for ducted or re-circulated extraction
- For recirculated extraction Clean Air Plus recirculation kit (accessory) needed

#### Design

- The clear glass panel provides a glass edge lighting and is extendable via lift motor
- The appliance comes in an extraordinary glass design equipped with white edge lighting. Simply choose your favorite color via Homeconnect.
- Top Frame suitable for seamless installation to create a unity with cooktop for a pure surface design

#### Comfort

- Electronic controls via touchControl
- The user interface to the left provides extended functions
- The standard functions are located on the right-hand user interface
- touchControl
- 3 speeds plus 2 intensive
- Automatic reset facility from intensive to normal setting
- Automatic revert setting, 6 minutes
- Automatic 10 minutes after running
- Air quality sensor
- Cooktop-based hood control
- (with matching cooktop)
- fully automatic hood

#### Features

- Activate Guided Air to guarantee nearly perfect extraction, regardless of pot height and pot position on the cooktop
- Ambient light RGB
- 
- The high quality filter cassettes with integrated metal grease filters are dishwasher safe
- Metal grease filter, dishwasher safe
- Saturation indicator for grease filter and odor filter
- The filter service button automatically lifts filters into service position for easy removal
- The glass panel can be easily removed and cleaned

#### Connectivity

- Home Connect for connected home appliances and operation via smartphone or tablet (only in countries where Home Connect service is available)
- The Home Connect functionality can be extended by integrating numerous applications from external cooperation partners (partnerships)
- Voice Control enabled via popular voice assistants (only in countries where this service is available)
- 
- interval function: available via Home Connect
- silence function: available via Home Connect

#### Performance

- Extraction rate according to EN 61591 ø 15 cm:
- max. Normal use 501 m<sup>3</sup>/h
- Intensive 775 m<sup>3</sup>/h
- Extraction rate exhaust air according to EN 61591:
- max. normal use 501 m<sup>3</sup>/h, intensive 775 m<sup>3</sup>/h
- Noise level according to EN 60704-2-13 exhaust air:
- Max. normal use: 62 dB(A) re 1 pW
- Intensive: 70 dB(A) re 1 pW
- Extraction rate according to EN 61591 ø 15 cm:
- max. Normal use 501 m<sup>3</sup>/h
- Intensive 775 m<sup>3</sup>/h
- Extraction rate exhaust air according to EN 61591 max. 775 m<sup>3</sup>/h
- Noise level according to EN 60704-2-13 at max. normal use exhaust air: 64 dB(A) re 1 pW dB(A) re 1 pW
- Noise min./max. Normal Level: 39/62 dB
- With the Clean Air Plus recirculation kit (available as optional accessory) your appliances reaches:
- Extraction rate in recirculation mode:
- Max. normal use: 416 m<sup>3</sup>/h
- Intensive: 525 m<sup>3</sup>/h
- Noise level in recirculation mode:
- Max. normal use: 65 dB(A) re 1 pW
- Intensive: 70 dB(A) re 1 pW
- Efficient BLDC-technology
- Max. extraction rate: 775 m<sup>3</sup>/h

#### Planning and installation information

- For seamless worktop installation a special accessory is required
- Suitable for installation into 90 cm cabinet
- Extension height 250 mm
- Dimensions (HxWxD): 709 x 812 x 140 mm
- Built-in dimensions (HxWxD): 703 x 781 x 123 mm
- 150 mm diameter pipe
- Electrical cable length 1.3 m
- For remote motor installation special accessory kit is needed
- Please reference the built-in dimensions provided in the installation drawing
- no combination with gas hobs allowed

#### Consumption Data

- Energy Efficiency Class: A (at a range of energy efficiency classes from A+++ to D)
- Average Energy Consumption: 36.9 kWh/year
- Blower Efficiency Class: A\*
- Lighting Efficiency Class: -
- Grease Filtering Efficiency Class: B
- Power rating: 300 W

\* In accordance with the EU-Regulation No 65/2014

## iQ700, downdraft hood, 80 cm, clear glass LD88WMM66

### Dimensioned drawings

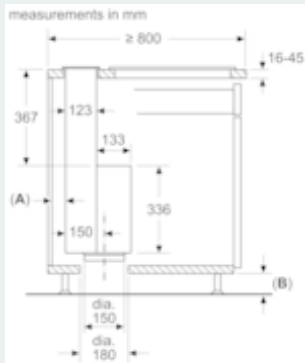

- A:** At least 2 cm from the Guided Air suction area to a unit wall  
**B:**  $\geq 60$  mm for air recirculation  
 $\geq 100$  mm for air extraction with ducting in the plinth

measurements in mm  
 Combination with electric hob

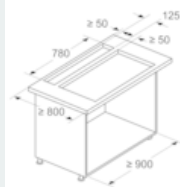

Use with gas hob not possible.

To ensure that the appliance does not lose any power, do not install any wall units above the appliance and maintain the following clearances:

- At least 50 cm to the left and right from the appliance to a wall or to an adjacent wall unit
- At least 5 cm from the frame of the appliance to a wall

**Planning information recirculation mode**  
 In case of installation in front of a poorly insulated external wall with a U-value  $>0.5W/(m^2K)$ , we recommend an air ducting up to the plinth panel in recirculation mode.

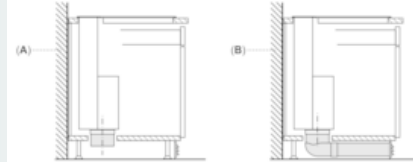

- A:** External wall - U-value  $\leq 0.5W/(m^2K)$   
**B:** External wall - U-value  $>0.5W/(m^2K)$

measurements in mm  
 Combination with electric hob  
 Seamless Installation

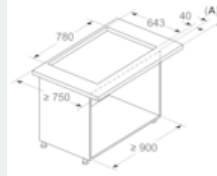

**A:** Worktop overhang furniture corpus

Use with gas hob not possible.

To ensure that the appliance does not lose any power, do not install any wall units above the appliance and maintain the following clearances:

- At least 500 mm to the left and right from the appliance to a wall or to an adjacent wall unit
- At least 50 mm from the frame of the appliance to a wall

measurements in mm

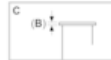
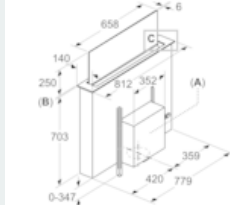

- A:** The motor unit can be fitted on the front or the rear or offset at a distance from the appliance. (Special accessory required)  
**B:** 5.5

measurements in mm  
 Seamless Installation  
 (Special accessory required)

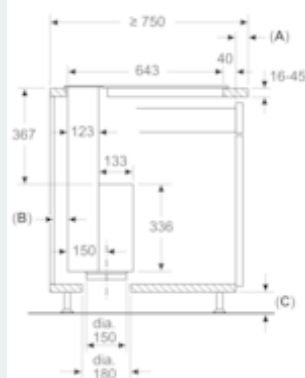

- A:** Worktop overhang furniture corpus  
**B:** At least 2 cm from the Guided Air suction area to a unit wall  
**C:**  $\geq 60$  mm for recirculation  
 $\geq 100$  mm for air extraction with ducting in the plinth