

iQ500, Built-In Microwave with grill, 59 x 38 cm, Black BE555LMB1



38 cm high built-in microwave for defrosting, reheating or preparation of dishes in the shortest possible time.

- ✓ Automatic programs ensure best results - cookControl8.
- ✓ For fast cleaning dirt is softened beforehand by vaporizing soapy water. It can then be removed more easily – humidClean.
- ✓ Foods are evenly browned - grill function.
- ✓ Allows the temperature to be controlled by entering it directly or by moving the slider with a single finger - touchControl.
- ✓ Time-saving and powerful up to 900 watts - Wattage.

Features

Technical Data

Type of micro-wave oven:	MW+Grill function
Type of control:	Electronic
Dimensions:	382x594x388 mm
Cavity dimensions:	208.0 x 328.0 x 369.0 mm
Length electrical supply cord:	130 cm
Net weight:	18.6 kg
Gross weight:	22.7 kg
Maximum micro-wave power ¹ :	900 W
Number of Power Levels:	5
Turntable:	Yes
Cavity material:	Stainless steel
Door opening:	Button
Clock:	Yes
Included accessories:	1 x grid, 1 x turntable
Height of the appliance:	382 mm
Width of the appliance:	594 mm
Depth:	388 mm
Maximum micro-wave power ¹ :	900 W
Connection rating:	1450 W
Fuse protection:	10 A
Voltage:	220-230 V
Frequency:	50 Hz
Plug type:	Gardy plug w/ earthing
Required cutout/niche size for installation (in):	x
Dimensions of the packed product:	17.32 x 18.50 x 29.92
Net weight:	41.000 lbs
Gross weight:	50.000 lbs



¹ Intelligent inverter technology: maximum output power will be regulated to 600 W when used in longer operation

iQ500, Built-In Microwave with grill, 59 x 38 cm, Black BE555LMB1

Features

Microwave and heating mode:

- Max. Power: 900 W; 5 Microwave power settings: 90 W, 180 W, 360 W, 600 W, boost
- Grill 1.2 KW
- Grill and microwave power levels 90 W, 180 W, 360 W combinable
- Microwave and grill for separate use
- Cavity volume: 25 l

Design:

- stainless steel cavity

Cleaning:

- humidClean (manually)

Comfort:

- LED display
- electronic clock
- Touchcontrol, touchSlider
- User-friendly electronics: extremely
- easy and comfortable operation
- cookControl 8
- 4 defrost and 3 cooking programmes in microwave function, 1 programmes for combination function
- Memory for individual programmes (1 setting)
- LED illumination
- 31.5 cm glass turntable
- side opening door, hinge left
- Electronic door opener
- Touch key operation

Accessory:

- 1 x grid, 1 x turntable

Environment and Safety:

- Door contact switch
- Integral cooling fan

Technical Information

- Length of mains cable: 130 cm
- Total connected load electric: 1.45 KW
- Nominal voltage: 220 - 230 V
- suitable for high cupboard installation

Dimensions:

- Appliance dimension (HxWxD): 382 mm x 594 mm x 388 mm
- Niche dimension (HxWxD): 380 mm - 382 mm x 560 mm - 568 mm x 550 mm
- "Please reference the built-in dimensions provided in the installation drawing"

**iQ500, Built-In Microwave with grill, 59 x 38 cm, Black
BE555LMB1**

Dimensioned drawings

Microwave, corner installation

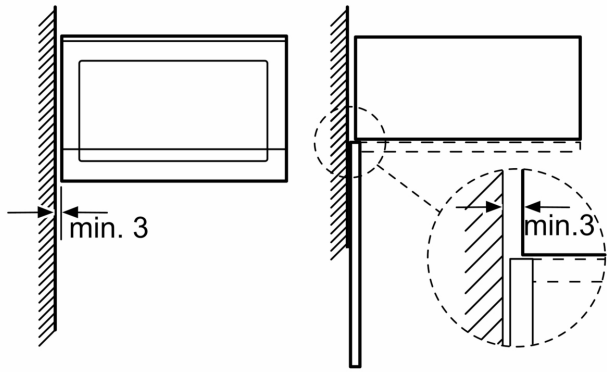

Measurements in mm

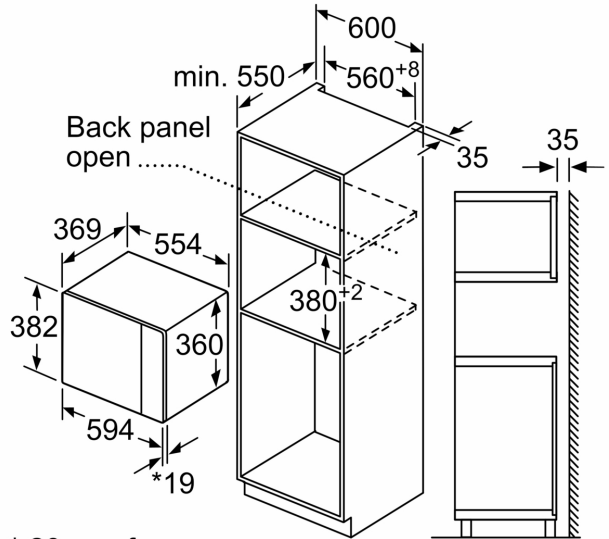

* 20 mm for metal fascia

measurements in mm

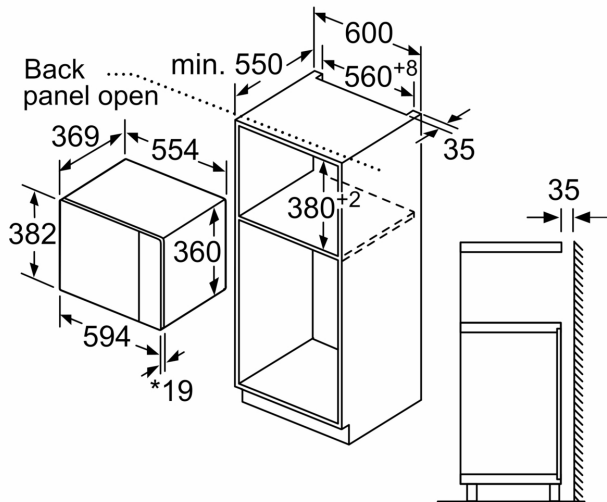

* 20 mm for metal fascia

measurements in mm

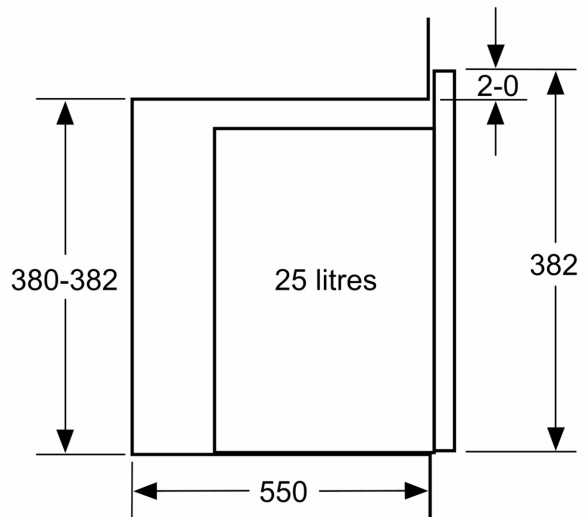

measurements in mm